



AN103 – EVD1000/1500 Circuit Example: BT656 Input/Output With Minimal Connections

INTRODUCTION

The EVD1000/1500 has a very flexible digital I/O structure, and in-circuit applications can be configured in a variety of fashions, utilizing different video data formats, levels of user control, etc. In this series of Application Notes, a number of examples are presented, each of which includes a complete set of schematic connections as required for operation in that particular example mode. For more complete and general application information, please refer to the EVD1000/1500 Data Sheet. The present Application Note describes the method of connection for a particularly simple and straightforward application, involving ITU-R BT656 video data input and output, and not requiring a microprocessor for control – a true single-chip solution.

Typical application – ITU-R BT656 Input/Output

The diagram shows a simple application with minimal connection to the EVD1000/1500 chip. The application enhances ITU-R BT656 format video so only the G_Y_IN and G_Y_OUT busses are used. The 8-bit input data is wired to the 8 most significant bits of the G_Y_IN bus and the output 8-bit data comes from the 8 most significant bits of the G_Y_OUT bus.

In ITU-R BT656 mode the CLK_VIDEO input is at twice the pixel rate, i.e. 27Mhz, and data changes on the G_Y_IN and G_Y_OUT busses at the same 27Mhz rate.

The Serial Configuration Bus is not used in this example, as the SDA and SCL pins are wired to VSS. Although the Serial Configuration Bus is not used the CLK_SYSTEM input must be wired to an active clock input, 27Mhz in this example. Since the Serial Configuration Bus is not used pullup resistors must be used on the R_CR_OUT and B_CB_CRCB_OUT busses to control various modes in the

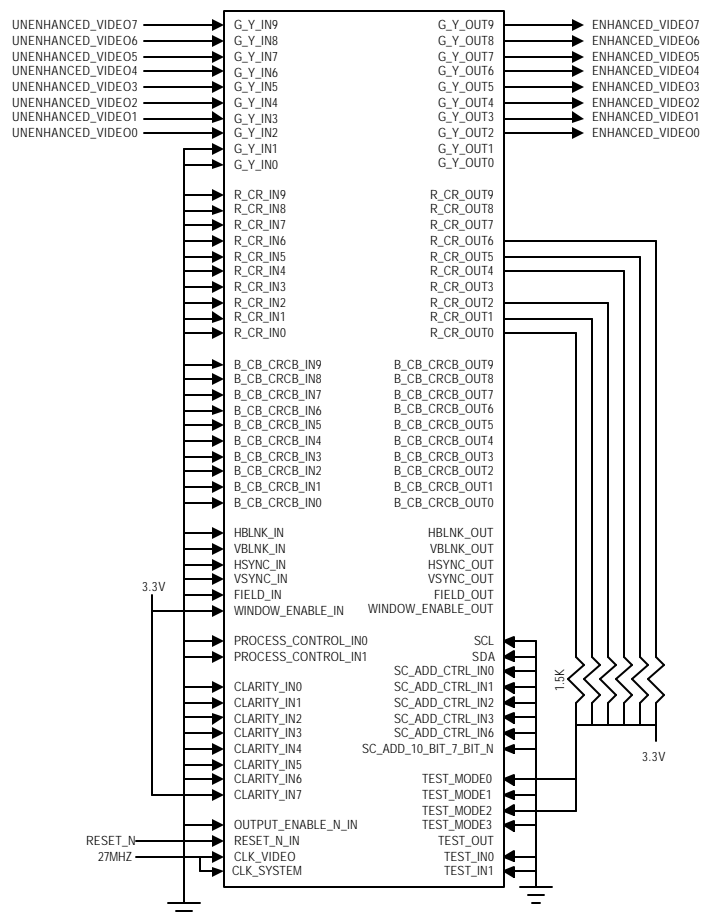



EVD1000/1500 chip. Pullups are placed on the R_CR_OUT1 and R_CR_OUT0 pins to make the input mode of the chip ITU-R BT656. A pullup is placed on R_CR_OUT2 to make the source for internal blanking signals be the SAV and EAV codes in the ITU-R BT656 video stream. Pullups are placed on the R_CR_OUT4 and R_CR_OUT5 pins to make the output mode of the chip ITU-R BT656. A pullup is placed on R_CR_OUT6 to force the EVD1000/1500 to insert EAV and SAV codes in the output stream. Pullups are not required on the R_CR_OUT[9:7] and B_CB_CRCB_OUT[2:0] pins because the HBLNK_IN, VBLNK_IN, FIELD_IN, HBLNK_OUT, VBLNK_OUT, and FIELD_OUT are not used. Pullups are not required on B_CB_CRCB_OUT[5:3] pins because Chroma Processing, Smart Grey, and Noise Filtering are not required in the application.

The PROCESS_CONTROL_IN[1:0] inputs are wired to VSS, causing the chip to enhance pixels for which WINDOW_ENABLE_IN is 1. WINDOW_ENABLE_IN is wired to 3.3V, causing the chip to enhance all pixels.

The bottom seven bits of the CLARITY_IN[7:0] bus are wired to VSS and the most significant bit of the bus is wired to 3.3V, causing the internal clarity value to be set to 128 decimal. This causes the chip to perform a medium amount of enhancement. Alternate wired settings are of course possible.

For further questions or clarifications, contact your sales representative or the factory for additional support.

Enhanced Video Devices, Inc.
9830 Summers Ridge Road
San Diego, CA 92121
858-530-0100

www.enhancedvideodevices.com

Copyright © 2009 Enhanced Video Devices, Inc. (EVD). All rights reserved. The information contained herein is subject to change without notice in order to improve design and/or performance. EVD products are protected under numerous U.S. and foreign patents and pending applications, maskwork rights, and copyrights. EVD assumes no responsibility or liability for the use of any of its information, products, or services, and conveys no license or title under any patent, copyright, or mask work right to its products, unless otherwise expressly specified and agreed in writing. Furthermore, EVD's products are not designed for use as critical components in life support, life saving, critical control or safety applications where a malfunction or failure may reasonably be expected to result in significant injury or harm. The inclusion of EVD products in such applications implies that the manufacturer assumes all risk of such use and in doing so fully indemnifies EVD against all damages resulting from such application. Any applications that are described herein are for illustrative purposes only.